

# 4G STICK D

for Autarco Inverters

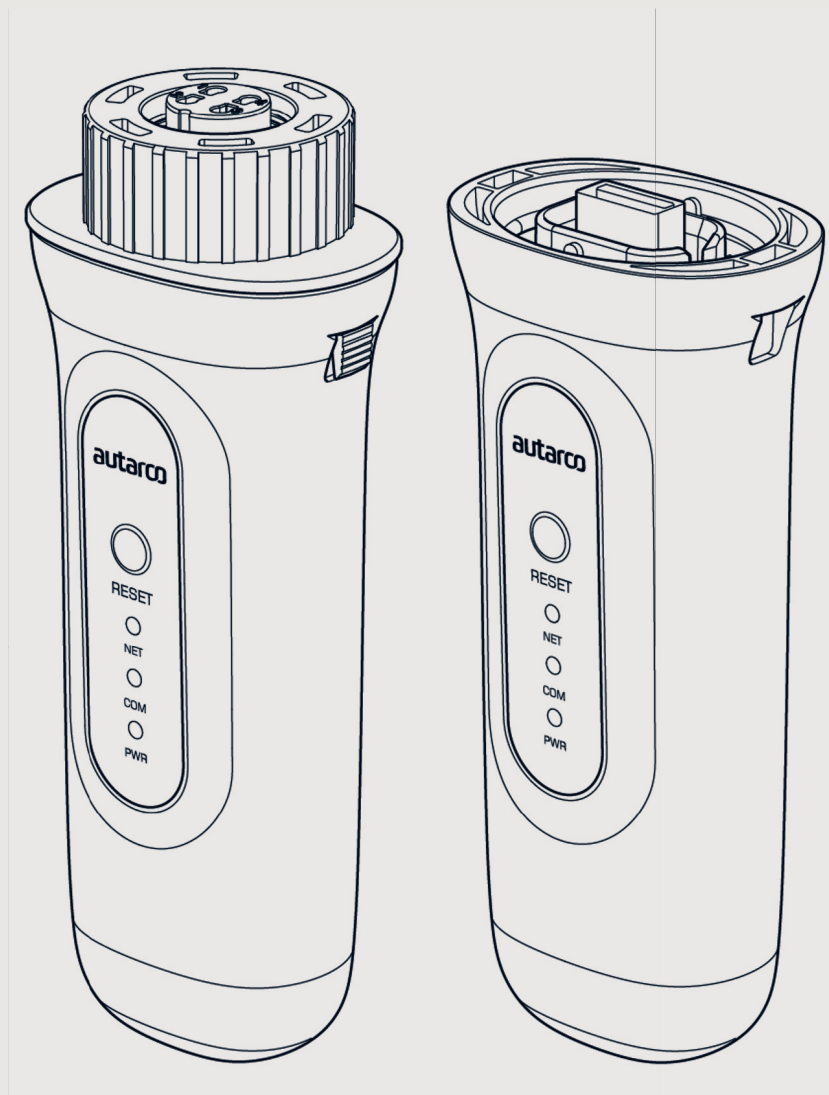



This manual is an integral part of the unit. Please read the manual carefully before installation, operation or maintenance. Keep this manual for future reference.

Product information is subject to change without notice. All trademarks are recognized as the property of their respective owners.

© Autarco Group B.V.  
All rights reserved.

**Contact**  
info@autarco.com  
www.autarco.com

**Address Torenallee**  
20 5617 BC  
Eindhoven The  
Netherlands

## 1 Installation 6

- 1 Read this first
- 1 Important symbols

## 2 Connection structure for 4G monitoring 7

- 2.1 Topology overview
- 2.2 When do you choose a 4G stick?

## 3 Installation 8

- 3.1 What type of SIM card is required?
- 3.2 Which SIM card size is required?
- 3.3 SIM card security code override (unlock)
  - 3.3.1 For Android
  - 3.3.2 For iPhone
- 3.4 Inserting SIM card
  - 3.4.1 Insert SIM Card in 4-pin communication stick
  - 3.4.2 Insert SIM Card in USB communication stick
- 3.5 Installation
  - 3.5.1 Installing 4-pin communication stick
  - 3.5.2 Installing USB communication stick
- 3.6 Connection with several inverters
- 3.7 Network configuration
  - 3.7.1 Local WiFi network configuration
  - 3.7.2 Public mobile network (4G) configuration
- 3.8 New stick's IP address after installation

## 4 Control 19

- 4.1 Does the stick have a connection?

## 5 Helios & MyAutarco 20

- 5 Registering stick in Helios
- 5 Customer registration for MyAutarco

5.3	Access MyAutarco monitoring platform (installer)	
5.4	Access MyAutarco monitoring platform (user)	
5.4.1	After installation of the stick by the installer	
5.4.2	After installation of the stick by the user	
5.4.3	Download MyAutarco App	
<b>6</b>	<b>Resetting the stick</b>	<b>22</b>
<b>7</b>	<b>Troubleshooting</b>	<b>23</b>
7.1	The stick has no power (red 'PWR' indicator is off)	
7.2	The red 'PWR' light is on, but the orange 'COM' light is off	
7.3	Signal quality	
7.4	Local router settings	
<b>8</b>	<b>FCC Certification</b>	<b>25</b>

## 1.1 Read this first

The purpose of this user manual is to provide instructions and a detailed description of procedures for installing, operating, maintaining and troubleshooting the Autarco 4G sticks. These 4G sticks can be used with all Autarco inverters. They can operate on both a WiFi as well as a 4G SIM card.

This manual is suitable for the following communication sticks:

- S2.4G-STICK-D.1 - For inverters with a 4-pin connection
- S2.4G-STICK-D.U1 - For inverters with a USB connection

Please keep this user manual available at all times.

## 1.2 Important symbols



**WARNING!** Indicates safety instruction, which if not correctly followed, can result in injury or property damages.

## 2.1 Topology overview

### 1. Inverter(s) with 4G STICK D

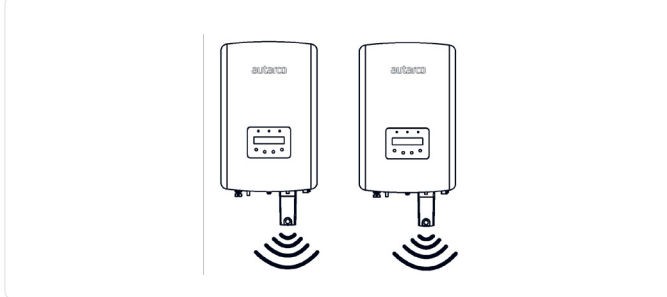

Inverter(s) communicate via 4G STICK D with a public mobile network or via WiFi with local router

### 2. Public mobile network (4G) or Local router (WiFi)



4 STICK D communicates via public mobile network or local router with the Autarco-server

### 3. <https://my.autarco.com>

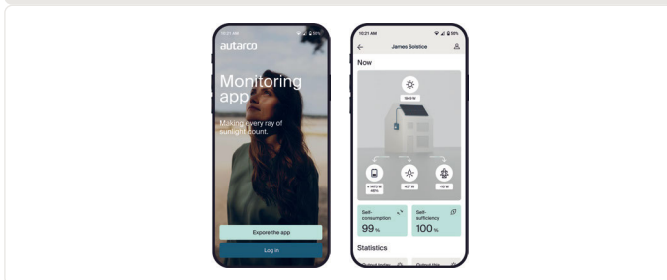

Monitoring data becomes visible in MyAutarco platform

## 2.2 When do you choose a 4G stick?

The advantage of monitoring over a 4G network is that in places where there is no Ethernet or WiFi (local network), an Autarco solar power system can still be monitored remotely.

**NOTE:** Monitoring with a 4G connection uses the public mobile network. This requires a (micro) SIM card and in most cases a subscription with an external provider for which costs are associated.

## 3.1 What type of SIM card is required?

To use the 4G stick you need an M2M or IoT SIM card. These cards have low monthly usage fees and limited bandwidth. Some providers of these SIM cards also have a portal to manage multiple cards.

A SIM card uses approximately 10 KB per inverter per day.

## 3.2 Which SIM card size is required?

You need a **micro SIM card** to operate the 4G stick.

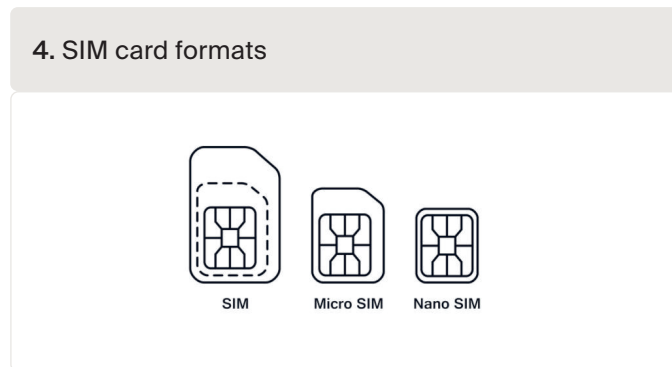

## 3.3 SIM card security code override (unlock)

If the SIM card has a PIN code, you must cancel or unlock it via a mobile phone. To unlock your SIM card, please take the following steps:

### 3.3.1 For Android



**WARNING!** Most smartphones these days use a SIM card in the so-called nano format. Ensure the SIM card size your phone uses before proceeding. You may need to have the SIM card cut to size and fit on an adapter again after canceling the security code. This is to be able to place the SIM card of the correct size back into the 4G stick.

1. Insert the SIM card into a phone (instead of your regular SIM card)
2. Go to 'Settings'
3. Choose 'Security'
4. Choose 'Set up SIM Lock'
5. Choose 'SIM card Lock'
6. Turn the 'Lock SIM card' option OFF
7. Choose 'OK'

The SIM card is now no longer locked.



### 3.3.2 For iPhone



**WARNING!** Most iPhones use a SIM card in the so-called nano format. If you want to use an iPhone, you will have to have the SIM card cut to size and fit on an adapter again after canceling the security code. This is to be able to place the SIM card of the correct size back into the 4G stick.

1. Insert the SIM card into a phone (instead of your regular SIM card)
2. Go to 'Settings'
3. Choose 'Mobile network'
4. Choose 'SIM PIN Code'
5. Turn OFF the 'SIM PIN Code' option
6. Enter the PI code to unlock the SIM card
7. Choose 'OK'

The SIM card is now no longer locked.

*\*The SIM card PIN code is stated with your new SIM card. If the SIM card has not been set up before, this PIN code is usually 0000.*

## 3.4 Inserting SIM card

After canceling the security code of the SIM card, it can be placed in the 4G stick.



**WARNING!** You need to access sensitive electronics to insert the SIM card into the 4G STICK D. Handle with care or you may damage the stick!

### 3.4.1 Insert SIM Card in 4-pin communication stick

1. Push the two tabs on the side of the stick
2. Pull out the circuit board from the protective housing
3. Place the SIM card on the circuit board
4. Place the circuit board back into the housing till you hear a click of the tabs

#### 5. Removing the protective housing for 4pin monitoring sticks

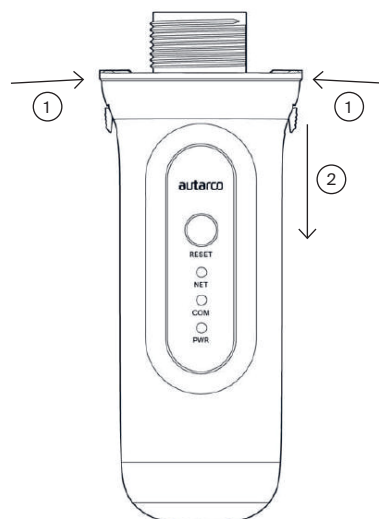

## 3.4.2 Insert SIM Card in USB communication stick

1. Gently push the two tabs at the top of the monitoring stick inwards to release the lock
2. Using a plier, gently hold the USB port and carefully remove the protective housing
3. Place the SIM card on the circuit board
4. Place the circuit board back into the housing
5. Once fully inserted, click the tabs outwards at the top of the USB monitoring stick to lock the circuit board back into place

### 6. Removing the protective housing for USB monitoring sticks

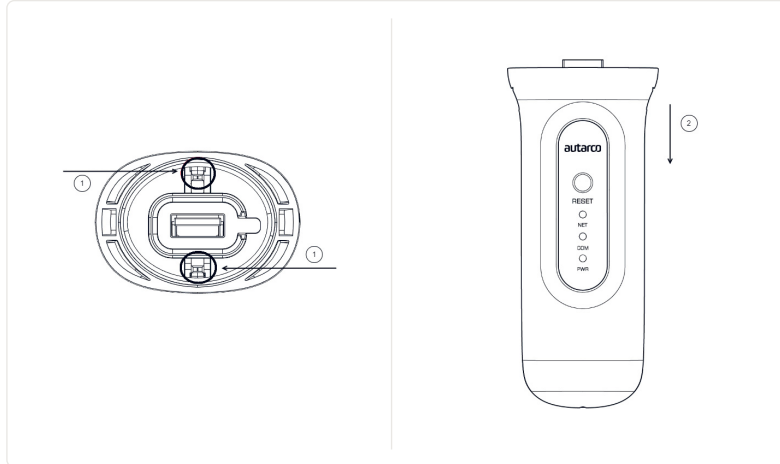

## 3.5 Installation

### 3.5.1 Installing 4-pin communication stick

1. Plug the 4G stick into the corresponding connection point of the inverter.

### 7. Connector Notch & COM port notch

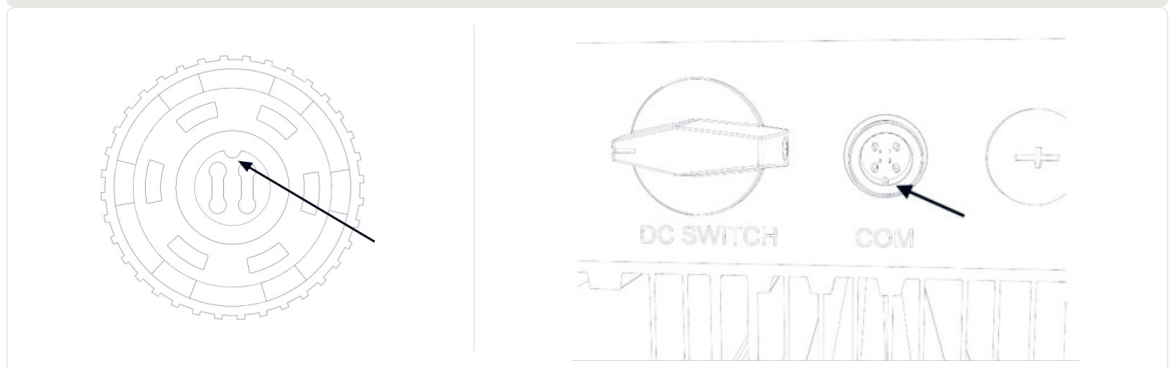

**ATTENTION!** Make sure that the position of the connecting piece of the stick is correct. Place the small notch on the connection point correctly so that the numbering of the 4-pin connector matches the numbering on the inverter.

2. Plug the 4G stick into the corresponding connection point of the inverter.

8. Connection point & stick

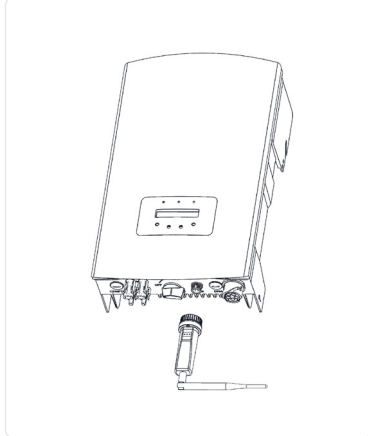

9. Stick installation

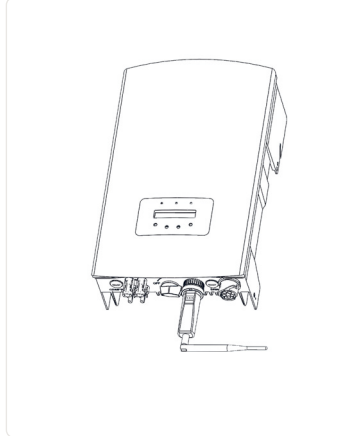

**WARNING!** To prevent damage, do not turn the black housing itself.

3.5.2

Installing USB communication stick

1. Plug the 4G stick into the corresponding connection point on the inverter.



**Note:** ensure that the position of the connection piece of the stick is correct. Match the joint indicated below on the inverter to correctly connect the USB connection.

10. USB connector notch & COM Port for Inverters with USB connection

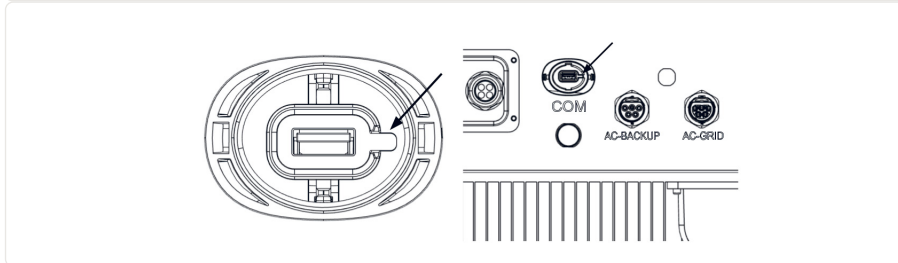

2. Press both sides of the USB port protective cover to open it. Align the 4G data logger with the USB port groove of the inverter and install directly.

11. Connection point & USB Stick installation

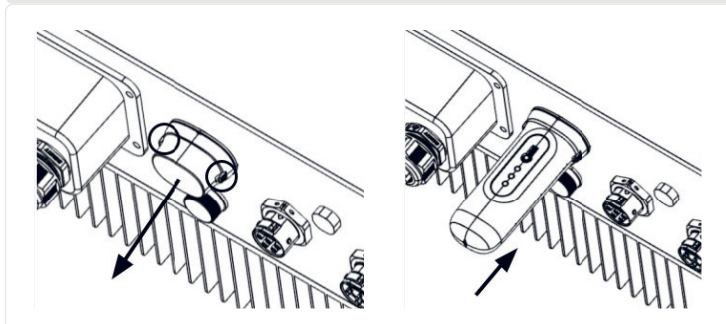

**WARNING!** Keep the 4G stick away from large metal objects and electrical appliances with magnetic fields such as microwave, refrigerator, mobile phone, concrete walls, solar panels and metal walls to ensure the quality of communication.

The 4G STICK D can also be used to read out several inverters. To do this, the inverters must be daisy-chained.

1. Connect multiple inverters in parallel with network cables.
2. Connect the 4G STICK D to the first inverter.
3. Set different addresses for each inverter. For example, if three inverters are connected, the address of the first inverter should be set to "01", the second inverter to "02", the third inverter to "03" and so on.
  - a. On the inverter, press ENTER and then UP/DOWN to navigate to the SETTINGS.
  - b. Select SET ADDRESS
  - c. Use UP/DOWN to select the correct address and press ENTER to save.
  - d. See the inverter manual for more information.

#### 12. Daisy-chaining multiple inverters

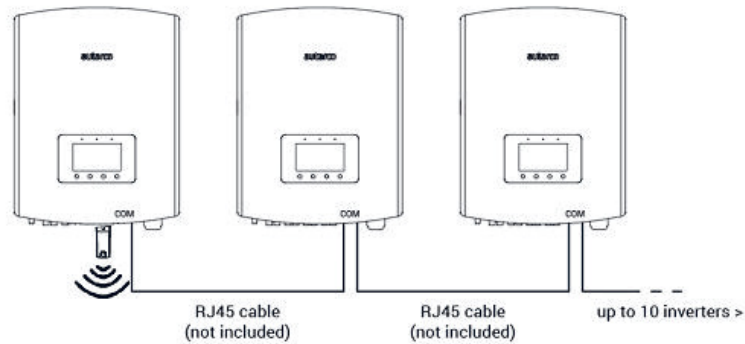

The default network mode of the device is to prioritize WiFi mode. When there is no WiFi or weak WiFi signal, the network mode will automatically switch to 4G communication (if the 4G signal is weak, it will be reduced to 2G for communication). When the WiFi network is restored, the WiFi communication will be automatically switched back.

The communication stick offers the following network operating modes:

- 4G + WiFi mode (recommended)** If you need the device's mode to switch between 4G and WiFi depending on the network conditions, please refer to sections 3.7.1 and 3.7.2 simultaneously. Autarco recommends always using this mode for your communication stick, even if you may not configure a WiFi network.
- 4G mode only** If you only need to use the 4G mode to communicate, please refer to section 3.7.1.
- WiFi mode only**  
If you only need to use the WiFi mode to communicate, please refer to section 3.7.2.

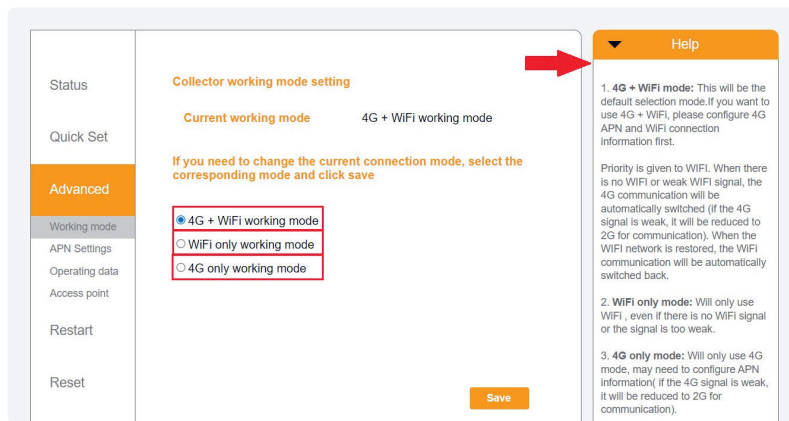

### 3.7.1

## Local WiFi network configuration

When the stick is connected to a generating inverter successfully, the red “PWR” indicator will turn on immediately. The orange “COM” indicator will start to flash and then turn solid. The “NET” indicator should be flashing.

If the PWR and/or COM LED is blinking or does not lit, go to chapter 6. Only proceed with the next steps after both PWR and COM indicators are on. You will now establish the connection between the monitoring device and Autarco’s server by using the existing on-site WiFi network.

This is done in two steps:

- Connecting to the local WiFi network of the stick.
- Entitle the stick to connect to the router on site via the stick’s online interface.

The stick can then use the local internet connection to send monitoring data via your local router to the Autarco server.

Proceed as follows:

1. Find the serial number of the stick.  
This is on a sticker on the front and back of the stick:



As an example we will use WiFi serial number 5F12092405500310.  
Your stick will have a different number.

1. Each WiFi stick creates its own secured wireless network with a network name: Autarco\_<serial number> e.g. "Autarco\_5F12092405500310". Connect to this wireless network with a computer, laptop, tablet or mobile phone and use the password below.

**Password:** 123456789

The figure shows an example of this screen in Windows:

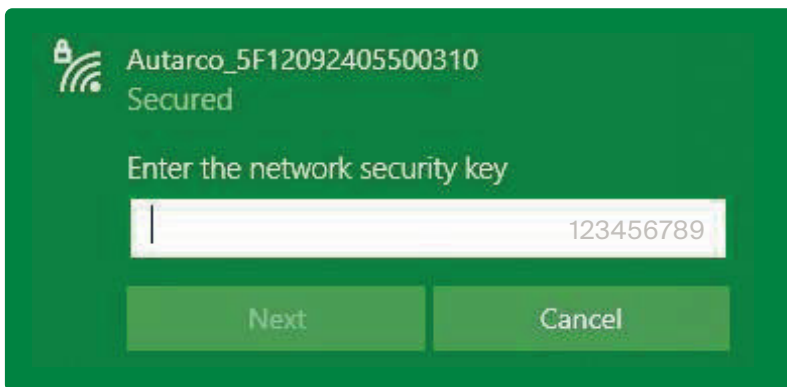

3. After you are connected to this WiFi network, enter the IP address 10.10.100.254 in the address bar of your web browser:

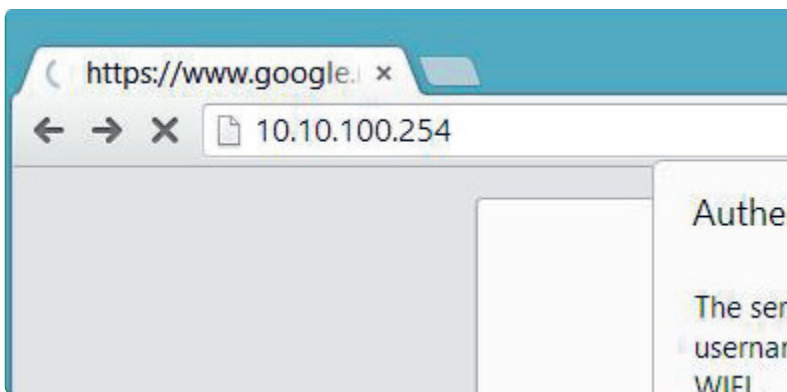

4. Access to the configuration interface of the WiFi stick is password protected. When prompted for the username and password, use the following credentials:

**Username:** admin

- Password:**
1. For devices delivered from Q4 2024 onward, a new password creation is needed. Please make sure between 6 and 15 characters are used, including at least one number and one letter.
  2. For older devices use the password "123456789"

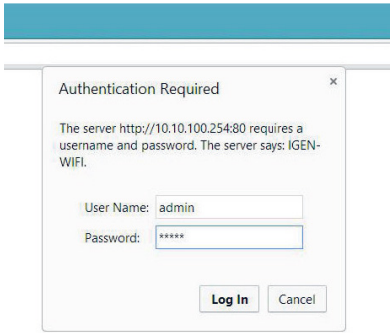

Old devices

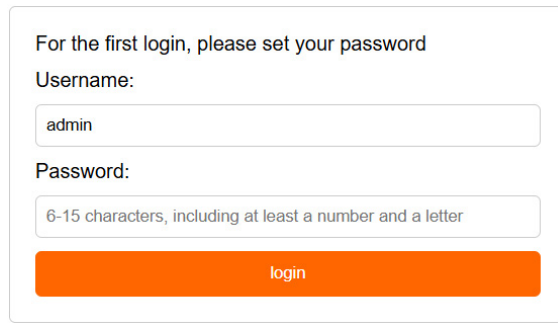

For devices delivered from Q4 2024 onward



**WARNING!** Passwords are case sensitive. If using an iPad, iPhone or other tablet device, please ensure that the first character of the password hasn't automatically become uppercase.

- Click Quick Set from the main menu on the left.  
\*If the menu is in Chinese, press English in the top right corner.

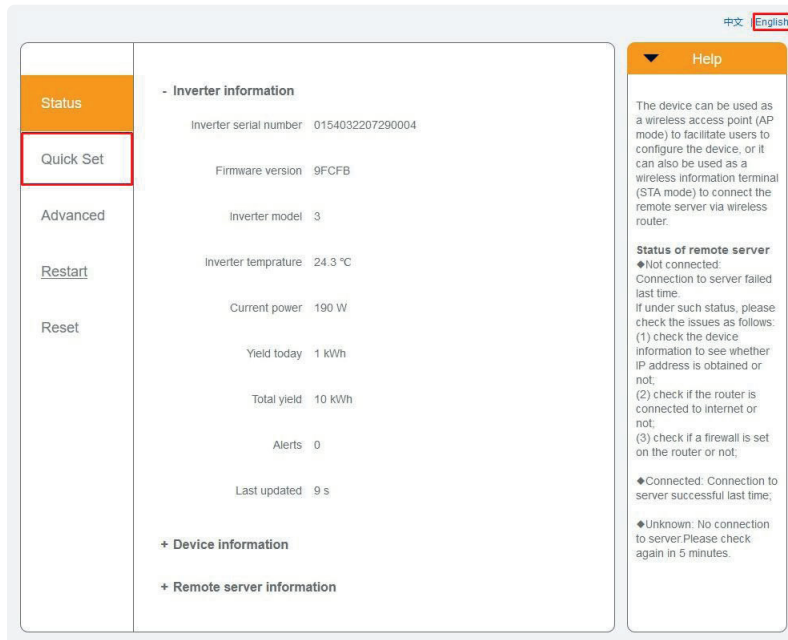

- Click SEARCH.

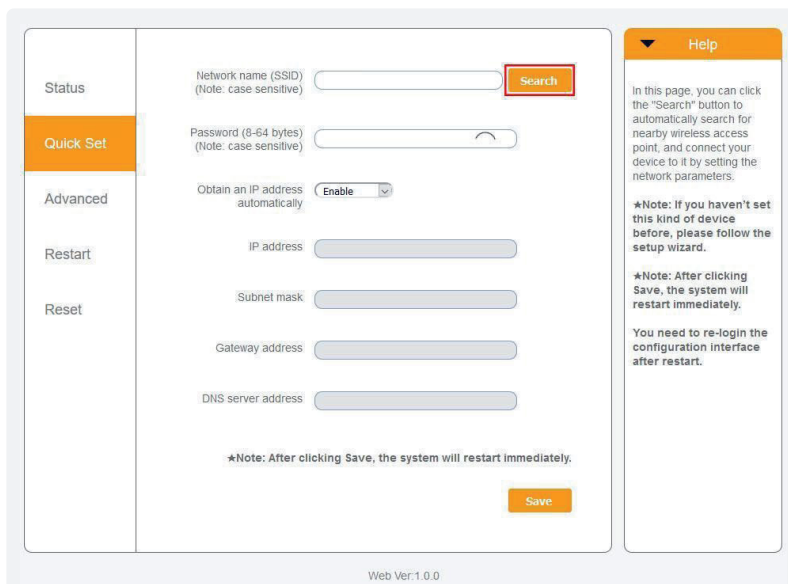

- A list of nearby WiFi networks will now appear. Find the WiFi signal of your own WiFi router and select it by clicking on the dot. This is the same WiFi network that you connect to on your home devices to use the internet. Click OK to continue. If your network is not listed, click Refresh and make sure the signal is present at the inverter location. For example, check whether this is the case on your phone. If the strength (RSSI) of the WiFi signal is lower than 30%, no or poor connection\* will be established with the inverter.

Site Survey	SSID	RSSI(%)	Channel
<input checked="" type="radio"/>	Your home Wi-Fi network	100	64
<input type="radio"/>	Wi-Fi Extender	100	64
<input type="radio"/>	Wi-Fi Repeater	100	64
<input type="radio"/>	Your neighbors Wi-Fi network	100	64
<input type="radio"/>	Ziggo-43643E	100	64
<input type="radio"/>	VRV9517UWAC34-A-99	100	64
<input type="radio"/>	Tinnie en Lauw wifi	80	96

⚠️Note: When RSSI of the selected WiFi network is lower than 15%, the connection may be unstable, please select other available network or shorten the distance between the device and router.

Buttons: OK, Refresh

- Enter your local WiFi network password. You can click on the eye icon to make the password visible. This is the same password that you use on other devices to connect to the Internet: it may be on the back of your router.

Network name (SSID) (Note: case sensitive): Your home Wi-Fi network [Search]

Password (8-64 bytes) (Note: case sensitive): [ ] [Eye icon]

Obtain an IP address automatically:  Enable

IP address: [ ]

Subnet mask: [ ]

Gateway address: [ ]

DNS server address: [ ]

⚠️Note: After clicking Save, the system will restart immediately.

Save



**WARNING!** Passwords are case sensitive. If you're using an iPad, iPhone, or other mobile device, make sure the first character of the password isn't automatically capitalized.

*\*Make sure the inverter is installed within range of your local WiFi network. If necessary, move your router or use a WiFi extender or an extra Access Point.*



- 9. A) If your local WiFi router is set up to assign IP addresses automatically, click Save to complete the installation. This is the most commonly used method.
- B) If you have a corporate network, disable the “Obtain an IP address automatically” option by Disable selecting, enter the next four fields and click Save to save.

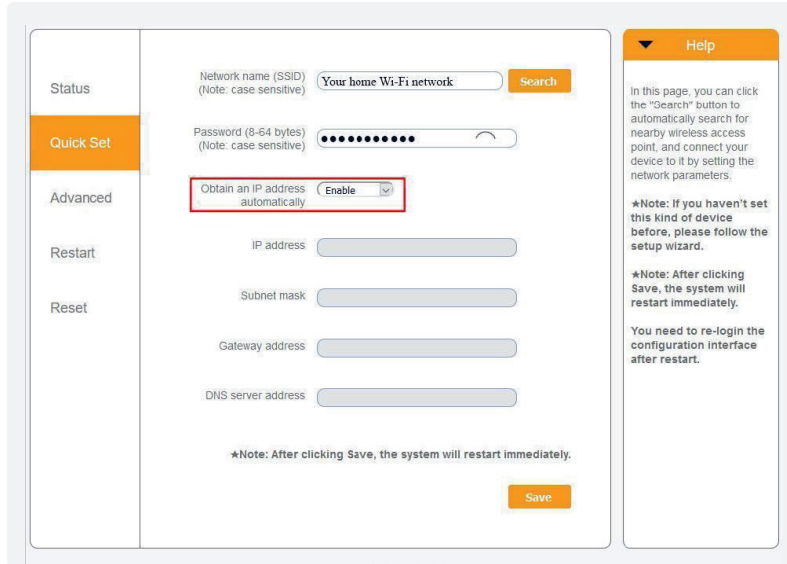

After you click Save , the WiFi stick will restart and try to connect to your WiFi network. If this is successful, the stick’s own WiFi signal will be disabled so that no one can log in to it. All three lights will now be solid.

- 10. The installation is complete when all three LEDs are solid. The LEDs will blink occasionally when the stick is transmitting data. The inverter is now connected to your local WiFi network and transmits its monitoring data to our Autarco server.

If the green light is not solid, try the following:

- Reconnect to the stick’s WiFi network/AP (Autarco\_<serial number>). If it doesn’t show up, press and hold the reset button on the stick for 15 seconds until the COM light (orange) and NET light (green) go out. This will reset the stick and will enable AP mode again.
- Repeat steps 1 to 8

Note: Always make sure that your router’s WiFi channel is set to 1 to 11 (not 12 or 13).

### 3.7.2 Public mobile network (4G) configuration

Before configuring a public mobile network on the communication stick, you must purchase a (micro) SIM card with an active 4G plan from your local carrier.



**ATTENTION!** Autarco does not supply SIM cards or Data packs.

Once a SIM card is inserted into the 4G STICK D, install the stick in the inverter (section 3.5) and the communication stick should recognize the APN.

Most SIM cards can be used directly after installation. You can find the APN settings in the SIM Card documentation, or contact your local network carrier for details.

If the SIM card cannot be connected normally, please follow the following steps to set the APN. Proceed as follows:

1. Follow the same steps 1 to 5 from Section 3.7.1 before proceeding
2. Click “Advanced”, and proceed to “APN Settings” Here you can set the APN settings for your SIM Card as required. When done, click save.

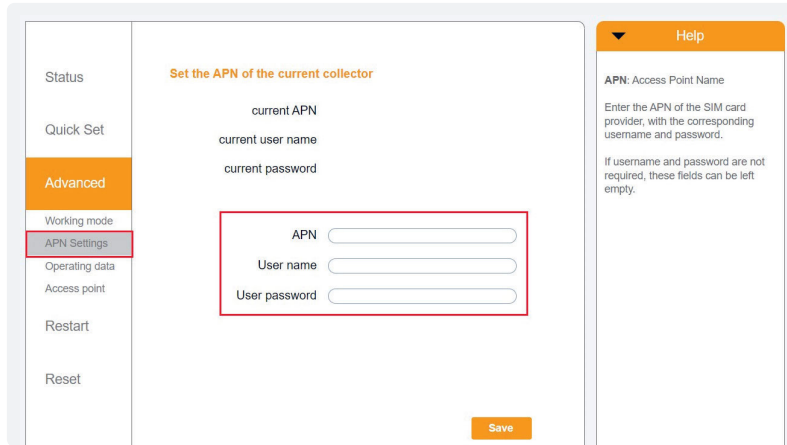

When the stick is connected to a generating inverter, the red “PWR” indicator will turn on immediately. The “COM” indicator will start to flash blue and then turn solid. The “NET” indicator should be flashing.

If the PWR and/or COM LED is blinking or does not light up, follow instructions in section 7. Only proceed with the next steps after both PWR and COM indicators are on.

## 3.8 New stick’s IP address after installation





After a successful connection, the stick’s IP address will change. To find out this IP address, log in to the router to find the new IP address in the list of connected devices. Some routers require you to switch off and on to refresh the list of connected devices.

## 4.1 Does the stick have a connection?

There are three green LED indicator lights on the 4G stick. The PWR light, or power light, indicates whether the stick is on (receives power). The COM light, or communication light, provides information about the communication between the stick and the inverter. The NET light, or network light, provides information about the communication between the stick and the Autarco server.

In the diagram on the next page you will find information about the meaning of the LED lights.

### 13. Summary of LED information

LED indicator	Status	Description
NET/Blue 	ON	The stick is connected to the Autarco server via 4G. The monitoring connection was successful. Monitoring data is forwarded.
	BLINKING	The stick is trying to connect to the 4G network.
	OFF	The stick does not connect to the Autarco server.
NET/Green 	ON	The stick is connected to the Autarco server via WiFi. The monitoring connection was successful. Monitoring data is forwarded.
	BLINKING	The stick is trying to connect to the Autarco server.
	OFF	The stick does not connect to the Autarco server.
COM/Orange 	ON	The stick can receive data from all connected inverters. A.
	BLINKING	The stick is processing data from an inverter, OR B. The stick is performing a software upgrade (if the green NET light is also flashing at the same time).
	OFF	The stick can <u>not</u> receive data from at least one of the connected inverters.
PWR/Red 	ON	The stick is powered (the stick is on).
	BLINKING	The stick is not getting enough voltage.
	OFF	The stick is not powered (the stick is off).

## 5.1 Registering stick in Helios

1. Go to the Helios design environment of the relevant system ([www.helios.autarco.com](http://www.helios.autarco.com))
2. Click on the arrow next to 'Asset management' in the bottom menu



3. Click on 'Monitoring setup'

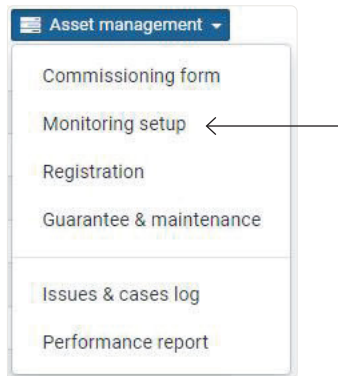

4. Enter the serial number of the 4G stick
5. Click 'Confirm'

Helios automatically checks whether monitoring messages are received. This can be found in the 'Monitoring messages' field.

## 5.2 Customer registration for MyAutarco

If monitoring messages are received after registration in Helios, the end customer will automatically receive an email with login details for the MyAutarco environment. This is possible if the end customer logs in at <https://my.autarco.com/> or in the MyAutarco app to view the monitoring data.

If no monitoring messages are received after registration in Helios, you will be given two options:

- a. You immediately send the login details to the end customer
- b. The login details are automatically sent to the end customer when the monitoring messages arrive

Once the Autarco server successfully receives monitoring messages, you need to link the data to the associated system (digital twin) in Helios and generate the MyAutarco login for the end user. End users should contact their installer for this.

By registering and linking the serial numbers of the installed products the software of Autarco knows to which system, inverter and string the received monitoring data must be linked. Then we start displaying the data in MyAutarco for both the dealer and the end user.



### NOTE TO THE INSTALLER

Before registering the system with Autarco, you must confirm the following from your customer regarding the creation of their monitoring and kWh warranty certificates:

- First name
- Last name
- Email address
- Phone number
- Installation address

## 5.4 Access MyAutarco monitoring platform (user)

### 5.4.1 After installation of the stick by the installer

You will receive your login details by email after the installer has registered your system with Autarco. You can access monitoring data on MyAutarco, via the website <http://my.autarco.com> or via the MyAutarco app.

### 5.4.2 After installation of the stick by the user

If you, as the owner of the solar power system, have installed a stick or have replaced a stick, it is necessary that the serial number is registered by your original installer. Only then will the monitoring work on the website and in the MyAutarco app.

Only if your installer can no longer help you, you can send an email to [support@autarco.com](mailto:support@autarco.com). Then we can register the serial number for you. For a quick processing, we need the following information:

- First name and last name
- Address (of installation)
- E-mail address
- **Serial number of newly installed stick**
- **Serial number of inverter**
- If applicable: serial number of removed stick

### 5.4.3 Download MyAutarco App

MyAutarco monitoring app is available on both Android and iOS devices. Here are three ways you can download and install the app:

1. Visit [www.autarco.com](http://www.autarco.com) to download the latest version of our app.

- You can simply search “MyAutarco” in Google Play or Apple App Store to find the latest version of our app.
- You may scan the QR code below to download the latest version of MyAutarco.

#### 14. MyAutarco installer app QR Code



## 6 Resetting the stick

The reset button on the stick has two functions:

- Force a message** Briefly press the reset button once to force a message that is immediately sent to the Autarco server.
- Perform reset** Press and hold the reset button for 15 seconds to reset the stick to factory settings. The COM light (blue / orange) and NET light (green) turn off temporarily. This reset will then re-enable the stick's 4G / WiFi Access Point (stick's 4G / WiFi network) so that you can redo the settings in chapter 3.



**WARNING!** DO NOT remove the 4G STICK D from the inverter.  
This is not necessary for reset.

#### 15. Reset button on stick

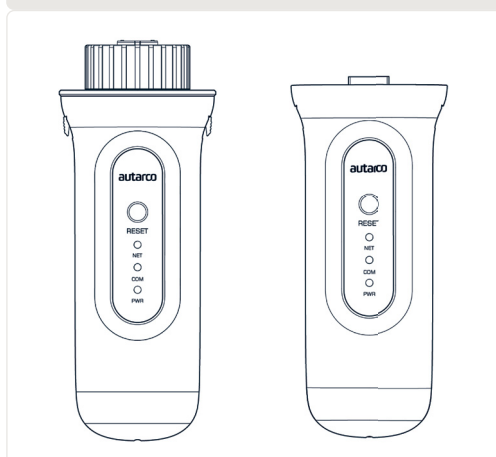

## 7.1 The stick has no power (red 'PWR' indicator is off)

If the inverter is powered on, the stick is installed correctly and the address setting in the inverter is <01>, but the red LED does not turn on, then the stick may be defective and/or the internal cables are broken.

Try installing another stick, making sure that you only use the black ring to tighten. NOT the blue housing) of the stick. Hold the stick with one hand and turn the black ring with the other hand.

## 7.2 The red 'PWR' light is on, but the orange 'COM' light is off

The 4G STICK D is powered (on), but cannot receive data from at least one of the connected inverters.

1. Briefly press the button on the back of the stick once (this will attempt to force a message).
2. Check the address setting\* of the inverter.

Address setting in inverter:

If the 4G STICK D only reads out one inverter, the address setting of the inverter must always be <01>. If the LAN-stick reads more than one inverter, the first inverter must be set to <01>. The other inverters must be numbered consecutively.

To check the inverter address, use the up and down buttons on the inverter, go to Settings > Set Address > select correct number > Enter.

\*This address is used to identify inverters when multiple inverters are read by one device.

## 7.3 Signal quality

The most common reason why the 4G STICK D cannot establish a good connection to the remote Autarco server is a weak 4G / WiFi connection to the network. Check whether the stick has a sufficient signal:

- Check the signal quality in chapter 3. A signal quality of 30% or more is sufficient.
- Check if your 4G data plan is still active.
- Check with your local data provider if there are any issues with the public mobile network.
- If the signal quality is less than 30%, please move the router closer to the inverter and the stick. If this is not possible, install one or more WiFi repeaters (also called WiFi extenders) between the local router and the inverter.
- Make sure that the network name (SSID) of the WiFi repeater is different from the network name of the router, for example by adding "-extended". By doing so, you ensure that the LAN-stick connects to the repeater and not directly to the router.
- Follow the instructions in chapter 3 after installing the WiFi repeater.

If the signal quality is insufficient, or if you cannot connect to the local WiFi network at all, check the settings below on the local router to ensure and optimize WiFi connectivity.

- Log in to the router by browsing the router's IP address using a computer, laptop, tablet, or mobile phone that is connected to the router's wireless network.

If you don't know the router's IP address, see the following web page:

[Find the IP address of your router](#)



**WARNING!** Autarco does not and cannot know the router username and password. Default usernames and passwords depend on the router brand and series.

Try changing the following settings on the router:

- Many routers are configured to use multiple protocols from the WiFi 802.11 family, eg b/g/n. Configure the router to use only 802.11n or only 802.11g. On some routers, the alternatives are 802.11b/g/n and 802.11b/g (so-called 'mixed modes'). In these cases, select the last option: 802.11b/g. You want to have as few protocols as possible 'mixed'.
- Make sure the wireless channel is between 1 and 11 .
- Set WiFi encryption to only one encryption type, such as WPA2-Personal or WPA2-PSK. Disable mixed or multiple encryption types.
- The stick can handle all characters, such as ! @ # \$ % & \* ( ) \_ + - = [ ] \ { } | ; : ' " , . / < > ? , but some characters are not allowed on all router/stick combinations. In case of problems, use only alphanumeric (letters and/or numbers) characters, such as az, AZ, A9 and 09 for the network name (SSID) and WiFi password.
- The router must dynamically assign IP addresses to connected devices. This is called DHCP (Dynamic Host Configuration Protocol). Please enable DHCP on the router.
- Some routers may require a region setting to work correctly. If so, choose a region setting.



**WARNING!** Changing some of these router settings may disconnect other connected devices such as computers, laptops, tablets or mobile phones. Please reconnect them with the new settings.



This device complies with part 15 of the FCC Rules.

Operation is subject to the following two conditions:

- (1) This device may not cause harmful interference, and
- (2) This device must accept any interference received, including interference that may cause undesired operation.



**FCC warning:**

Any Changes or modifications not expressly approved by the party responsible for compliance could void the user's authority to operate the equipment.



**Note:**

This equipment has been tested and found to comply with the limits for a Class B digital device, pursuant to part 15 of the FCC Rules. These limits are designed to provide reasonable protection against harmful interference in a residential installation.

This equipment generates uses and can radiate radio frequency energy and, if not installed and used in accordance with the instructions, may cause harmful interference to radio communications. However, there is no guarantee that interference will not occur in a particular installation.

If this equipment does cause harmful interference to radio or television reception, which can be determined by turning the equipment off and on, the user is encouraged to try to correct the interference by one or more of the following measures:

- Reorient or relocate the receiving antenna.
- Increase the separation between the equipment and receiver.
- Connect the equipment into an outlet on a circuit different from that to which the receiver is connected.
- Consult the dealer or an experienced radio/TV technician for help.

This equipment complies with FCC radiation exposure limits set forth for an uncontrolled environment. This equipment should be installed and operated with a minimum distance 20cm between the radiator & your body.